

HYVA CYLINDER



715 36 624

Front end cylinder with eye

type

FE 169-5-07200-005C-K1864

tipping weight

26-37 ton

page # 1 / 2

closed length (K)

1859-1894 mm

front & side view cylinder

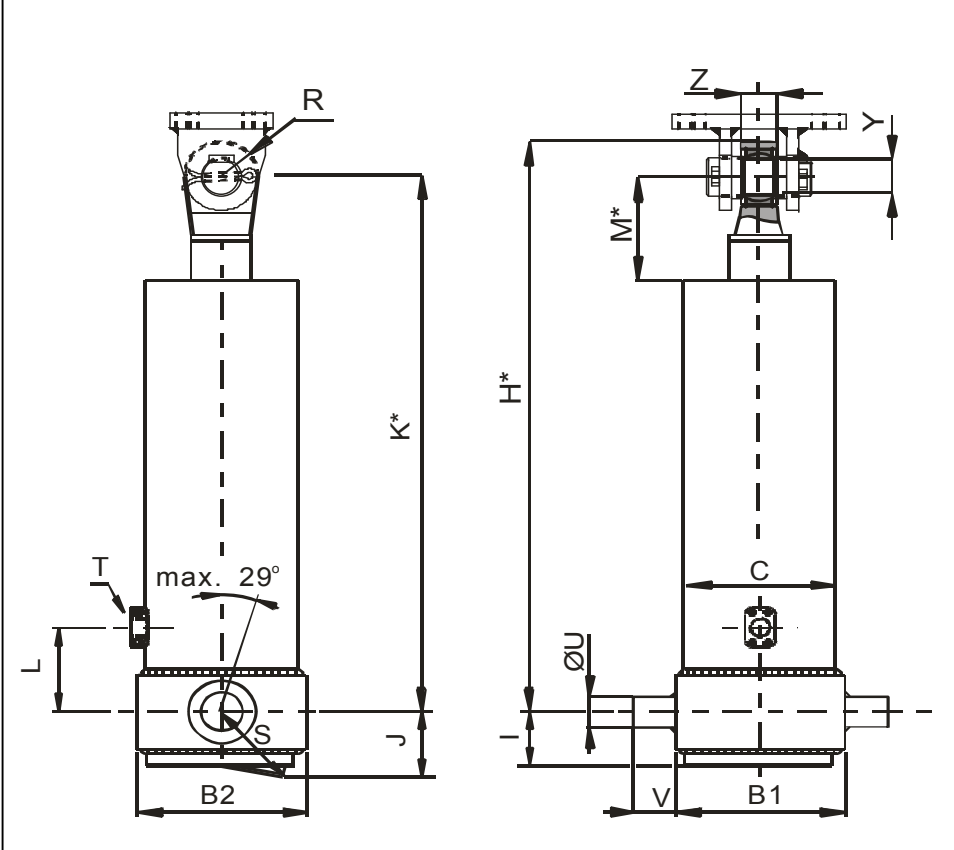

	1	2	
A			mm
B	245	224	mm
C	191		mm
D			mm
E			mm
F			mm
G*			mm
H*	1917		mm
I	65		mm
J	106		mm
K*	1864		mm
L	190		mm
M*	100		mm
N			mm
O			mm
P			mm
Q			mm
R	53		mm
S	127		mm
T	1" SAE		
U	60		mm
V	65		mm
W			mm
X			mm
Y	50		mm
Z	42		mm

*incl.20 [-5;+30] mm pull out on piston

specifications

weight cylinder only	285 kg
total volume	112 L
working volume	103 L
maximum pressure	150 bar
maximum pump flow	137 L/min
maximum cylinder angle to front	30 °
maximum thrust first stage**	35 ton

**when cyl. mounted at a large angle, thrust first stage may become too high: see Hyva Tipper Program

technical notes

This cylinder is a lifting device only and may not be used as structural member or be subject to side load. Working pressure depends on application; never exceed maximum pressure stated. Cylinder is painted black (RAL9005). Max duration of extension 0.5 hours (excluded HC). See specification sheet CYL-0019 for mounting instructions, OIL-0011 for oil specifications and 015BRA01 for bracket specifications.

extension	1	2	3	4	5	6	7	8	9	
effective diameter [mm]	169	149	129	110	91					total
stroke [mm]	1510	1530	1530	1530	1100					7200

tipping weight

tipping weight at maximum pressure of 150 bar and C is 158 mm

BL (body length); OH (rear overhang); X=Ycog (vert. pos. centre of gravity); Qo (pivot length); C (bracket length); At = stroke x 60 / Qo	BL	9500			9300			9100		
		OH	200	500	800	200	500	800	200	500
	At	46	47	49	47	48	50	48	50	51
	Ycog									
	600	26	28	30	26	28	30	27	29	31
	900	28	29	32	28	30	33	29	31	34
	1200	29	31	34	30	32	35	30	33	37

HYVA CYLINDER



715 36 624

Front end cylinder with eye

type

FE 169-5-07200-005C-K1864

page # 2 / 2

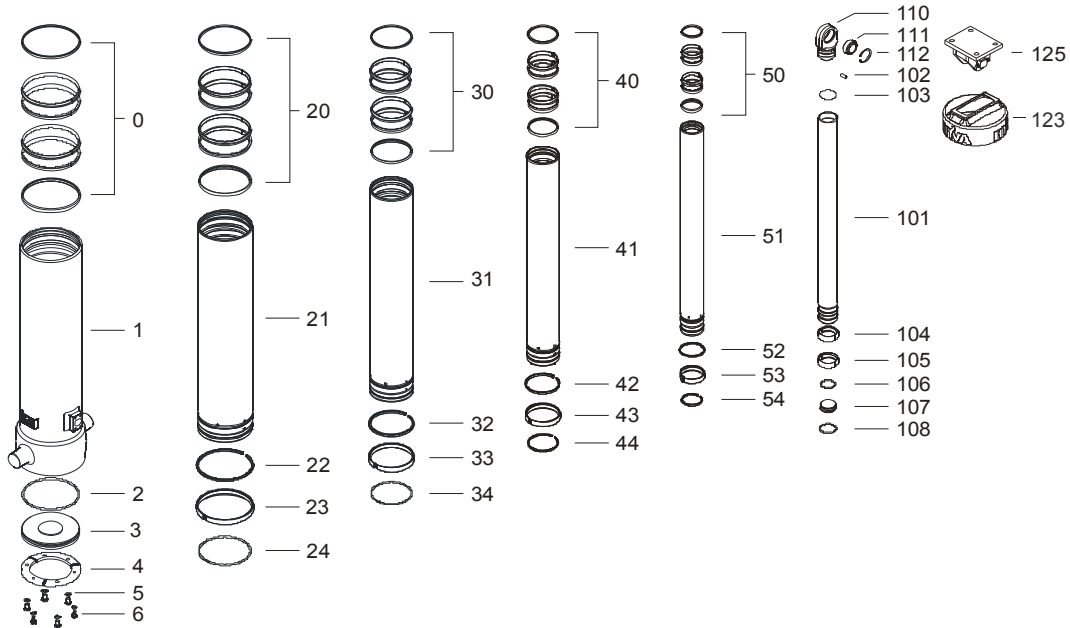

Spare part list

Pos	Part no.	Description	Qty.
0	71802191 K	PACKSET FL 191	01
1	72507720	BASE 191-1819-4/4SAE-190	01
2	71870040 K	SEAL BOTTOM PLATE 191	01
3	71821191	BOTTOM PLATE 191	01
4	71820191	LOCKING PLATE 191	03
5	01732559 K	SPRING WASHER M8 SET	01
6	01732055 K	BOLT M8 X 1.25 X 20 SET	01

20	71802169 K	PACKSET FL 169	01
21	72606720	STAGE 169-1780	01
22	71811169 K	OUTER STOPRING FL 169	01
23	71807169 K	SLIDER FL 169	01
24	71813169 K	LIFTRING FL 169x5	01

30	71802149 K	PACKSET FL 149/HP 150	01
31	72605720	STAGE 149-1780	01
32	71811149 K	OUTER STOPRING FL 149	01
33	71807149 K	SLIDER FL 149	01
34	71812149 K	LIFTRING FL 149/HP 150	01

40	71802129 K	PACKSET FL 129/HP 129	01
41	72604720	STAGE 129-1780	01
42	71811129 K	OUTER STOPRING FL 129/HP 129 HD	01
43	71807129 K	SLIDER FL 129/GF 129 (2 X 1/2)	01
44	71812129 K	LIFTRING FL 129/HP 129	01

Seal kit complete:

Part no.	Description
71901650 K	Seal kit complete: consists of all packsets with packset grease, O-rings and Pin (pos.102)

Spare part list

Pos	Part no.	Description	Qty.
50	71802110 K	PACKSET FL 110	01
51	72603720	STAGE 110-1780	01
52	71811110 K	OUTER STOPRING FL 110/HP 110 HD	01
53	71807110 K	SLIDER FL 110/GF 110 (2 X 1/2)	01
54	71812110 K	LIFTRING FL 110	01

101	72402727	PISTON S 091-1785-HC (SR=430)	01
102	71875012	PIN ROUND HEAD GROOVED 8x15 mm	02
103	71870115 K	O-RING PISTON TOP 091	01
104	71811091 K	OUTER STOPRING FL 091/HP 091 HD	01
105	71807091 K	SLIDER FL 091 (2 X 1/2)	01
106	71870215	O-RING PISTON BOTTOM 091	01
107	71822091	BOTTOM PLATE PISTON 091	01
108	01745012	CIRCLIP 82 DIN 472 (87.5x2.5)	01
110	71835091	PISTON EYE SPH. 091 MACHINED+SPH.EY	01
111	71875450	SPHERICAL EYE D.50 MAINT. FREE	01
112	01770560	CIRCLIP GE 50 DO	01
123	71838960	DUST COVER FE 169 YELLOW	01

125	01506785	TOP BRACKET FE(E) 149-191 SPECIAL PIN	01
-----	----------	---------------------------------------	----

Notes:

The inner and outer stoprings are pre-mounted in the grooves on spare stages and pistons. Therefore, when ordering new tubes, it is not required to order stopring separately.