

HYVA CYLINDER

714 36 823



type: UME 169-6-2740-K221-50-3/4"-HC

tipping weight: 13-29 ton

page # 1 / 1

Stage diameters 169 149 129 110 91 72	front view cylinder		A 230 ØC 192 G¹ 692 I 441 K¹ 221 H¹ 62 N 30 ØP 69 ØY 35.5 S 451 ØW 50 X 45
---	---------------------	--	---

¹including 20 mm pull-out [tol. -5; +30 mm]

²cylinder is delivered including oil inlet swivel adapter

specifications

total stroke ¹	2740 mm
dry weight cylinder only	111 kg
total volume	36.2 L
working volume	33.3 L
maximum pressure	220 bar
maximum pump flow	61 l/min
maximum allowable thrust first stage ³	23.0 ton
oil inlet	3/4" BSP

technical notes

This cylinder is a lifting device only and may not be used as a structural member or be subjected to side load. Sideload and/or poor alignment might result in cylinder leakage.

Hyva therefore strongly recommends the use of a cradle, even in instances where the cylinder only tips to the rear or to the side. The cylinder is painted black RAL9005.

For suitable hydraulic oils, please refer to data sheet OIL-0011. For details of available brackets and cradles, please refer data sheet 015BRA06.

Detailed calculations can be made using the HYVA Tipper Program, freely available from tipper.hyva.com.

³The cylinder thrust on the first stage (from the HYVA Tipper Program) must not exceed the maximum allowable (see specifications above).

tipping view

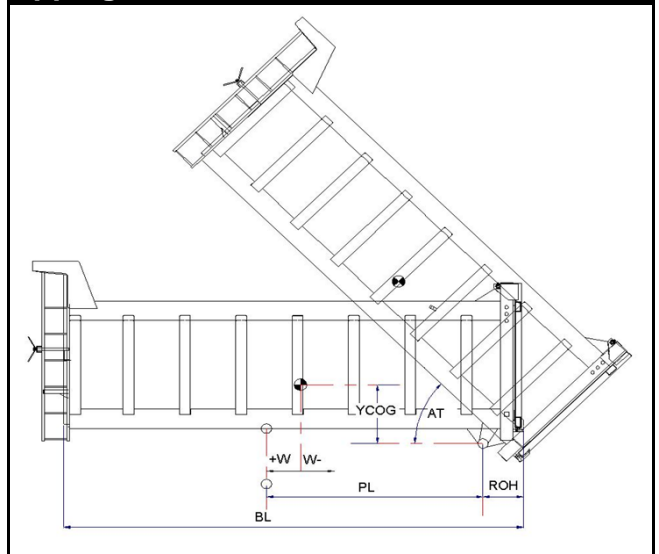

tipping weight

AT	46	deg	52
PL	3570	mm	3160
YCOG	700	mm	700
ROH	700	mm	700
BL	8540	mm	7720
	7760	mm	7020
	7120	mm	6430
CYL w.r.t. COG (W)	0	mm	0
	390	mm	350
	710	mm	640
Tipping weight for full stroke of 46°			
Tipping weight for full stroke of 52°			
Tipping weight	13	ton	14
	15	ton	17
	17	ton	19
Tipping weight for second last stage, up to 38°			
Tipping weight for 2nd last stage, up to 43°			
Tipping weight	18	ton	21
	24	ton	26
	27	ton	29

HYVA CYLINDER

714 36 823

type

UME 169-6-2740-K221-50-3/4"-HC

page # 2 / 2

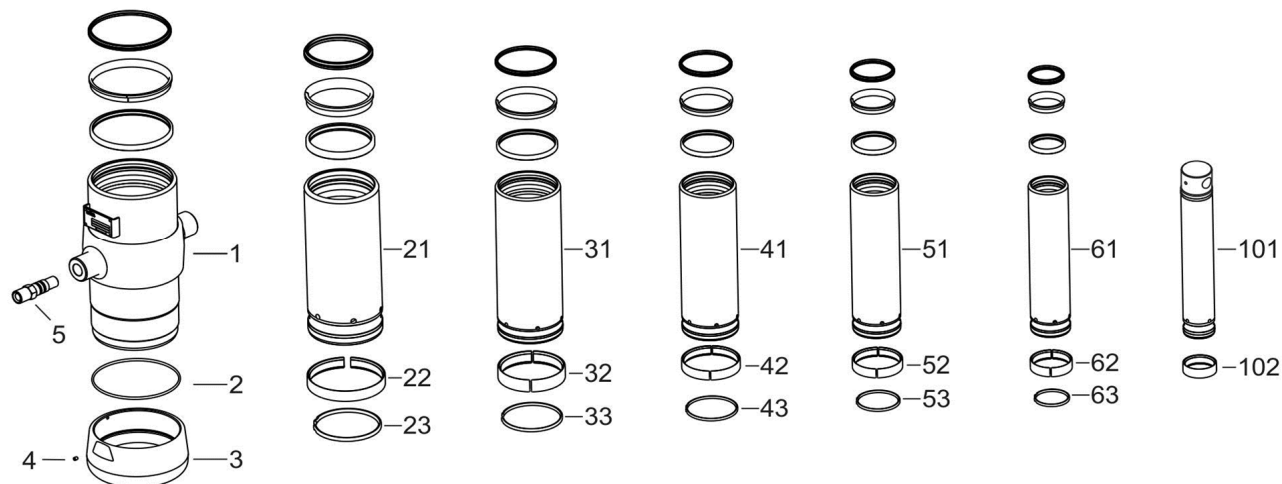

Spare part list

Pos	Part no.	Description	Qty.
1	73507700	BASE 191-0572-N0159	1
2	01226780	O-RING 184 X 4 70 SHORE	1
3	73101050	THREADED BOTTOM UM 191	1
4	01792571	LOCKING SCREW M6X12 INT. HEX. DIN 916	1
5	73103002	OIL INLET ADAPTOR UM 3/4"OT+O-RING	1
21	73606701	STAGE 169-0572-HC	1
22	71807169 K	SLIDER FL 169	1
23	71813169 K	LIFTRING FL 169x5	1
31	73605701	STAGE 149-0572-HC	1
32	71807149 K	SLIDER FL 149	1
33	71812149 K	LIFTRING FL 149/HP 150	1
41	73604701	STAGE 129-0572-HC	1
42	71807129 K	SLIDER FL 129/GF 129 (2 X 1/2)	1
43	71812129 K	LIFTRING FL 129/HP 129	1
51	73603701	STAGE 110-0572-HC	1
52	71807110 K	SLIDER FL 110/GF 110 (2 X 1/2)	1
53	71812110 K	LIFTRING FL 110	1

Spare part list

Pos	Part no.	Description	Qty.
61	73602701	STAGE 091-0572-HC	1
62	71807091 K	SLIDER FL 091 (2 X 1/2)	1
63	71812091 K	LIFTRING FL 091	1
101	73431701	PISTON E 072-0614-HC	1
102	71807072 K	SLIDER FL 072 (2 X 1/2)	1

Seal kit complete

Part no.	Description
719 04 661K	Complete packset: Consists of all packsets with packset grease and o-ring.