

HYVA CYLINDER



715 06 417

Front end cylinder with outer cover

type

FC 169-5-05355-074A-K0900-HC

tipping weight

35-69 ton

page # 1 / 2

closed length (K)

895-930 mm

front & side view cylinder

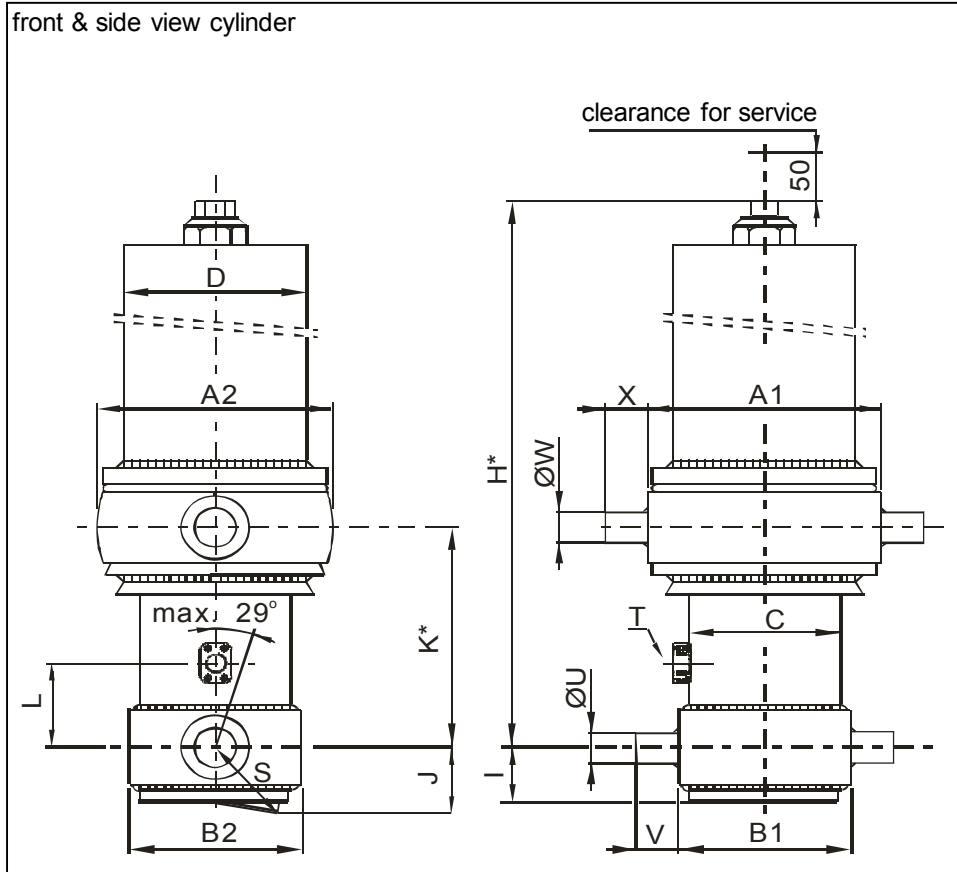

	1	2	
A	340	329	mm
B	245	224	mm
C	191		mm
D	242		mm
E			mm
F			mm
G*			mm
H*	1394		mm
I	65		mm
J	106		mm
K*	900		mm
L	290		mm
M*			mm
N			mm
O			mm
P			mm
Q			mm
R			mm
S	127		mm
T	1" SAE		
U	60		mm
V	65		mm
W	60		mm
X	65		mm
Y			mm
Z			mm

*incl.20 [-5;+30] mm pull out on piston

specifications

weight cylinder only	265 kg
total volume	80 L
working volume	74 L
maximum pressure	190 bar
maximum pump flow	137 L/min
maximum cylinder angle to front	20 °
maximum thrust first stage**	35 ton

**when cyl. mounted at a large angle, thrust first stage may become too high: see Hyva Tipper Program

technical notes

This cylinder is a lifting device only and may not be used as structural member or be subject to side load. Working pressure depends on application; never exceed maximum pressure stated. Cylinder is painted black (RAL9005).

Max duration of extension 0.5 hours (excluded HC). See specification sheet CYL-0019 for mounting instructions, OIL-0011 for oil specifications and 015-BRA01 for bracket specifications.

extension	1	2	3	4	5	6	7	8	9	
effective diameter [mm]	169	149	129	110	91					total
stroke [mm]	1055	1075	1075	1075	1075					5355

tipping weight

tipping weight at maximum pressure of 190 bar and C is 229 mm

BL (body length); OH (rear overhang); X=Ycog (vert. pos. centre of gravity); Qo (pivot length); C (bracket length); At = stroke x 60 / Qo	BL	7100			6800			6500		
	OH	200	500	800	200	500	800	200	500	800
At	45	47	49	47	49	52	49	52	55	
Ycog										
600	35	38	43	36	40	45	38	42	49	
900	38	42	48	40	45	52	42	48	57	
1200	41	47	54	44	50	60	47	55	69	

HYVA CYLINDER

715 06 417



Front end cylinder with outer cover

type

FC 169-5-05355-074A-K0900-HC

page # 2 / 2

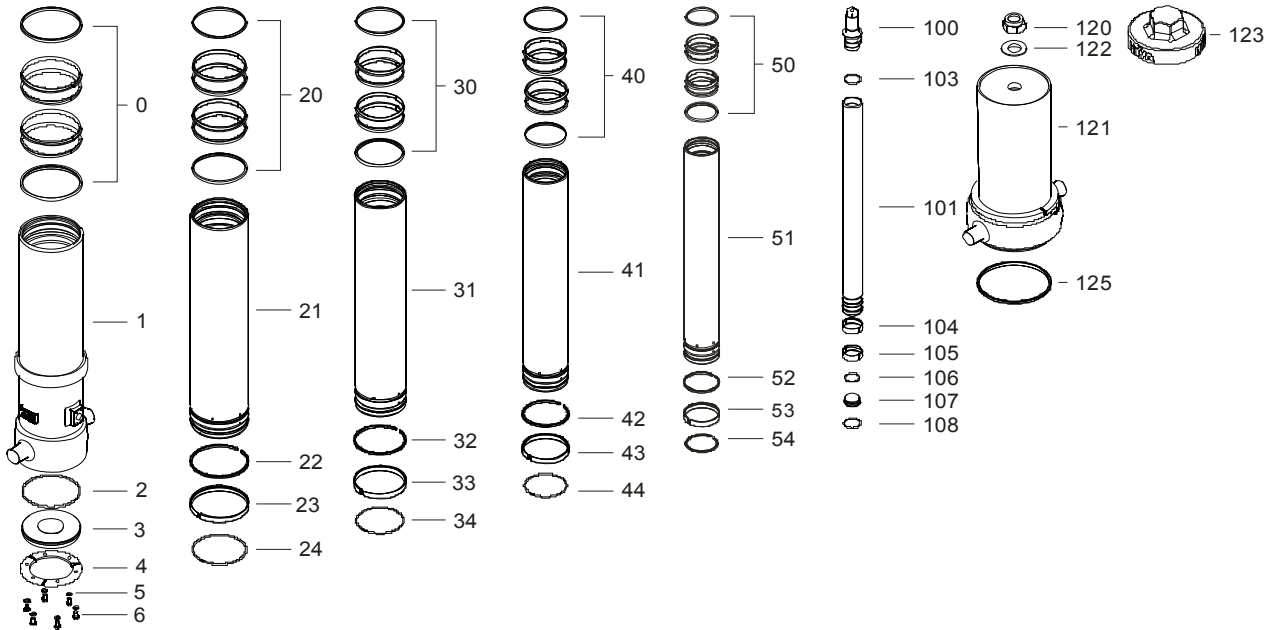

Spare part list

Pos	Part no.	Description	Qty.
0	71802191 K	PACKSET FL 191	01
1	72507303	BASE 191-1314-4/4SAE-290-90	01
2	71870040 K	SEAL BOTTOM PLATE 191	01
3	71821191	BOTTOM PLATE 191	01
4	71820191	LOCKING PLATE 191	03
5	01732559 K	SPRING WASHER M8 SET	01
6	01732055 K	BOLT M8 X 1.25 X 20 SET	01

20	71802169 K	PACKSET FL 169	01
21	72606301	STAGE 169-1275-HC	01
22	71811169 K	OUTER STOPRING FL 169	01
23	71807169 K	SLIDER FL 169	01
24	71813169 K	LIFTRING FL 169x5	01

30	71802149 K	PACKSET FL 149/HP 150	01
31	72605301	STAGE 149-1275-HC	01
32	71811149 K	OUTER STOPRING FL 149	01
33	71807149 K	SLIDER FL 149	01
34	71812149 K	LIFTRING FL 149/HP 150	01

40	71802129 K	PACKSET FL 129/HP 129	01
41	72604301	STAGE 129-1275-HC	01
42	71811129 K	OUTER STOPRING FL 129/HP 129 HD	01
43	71807129 K	SLIDER FL 129/GF 129 (2 X 1/2)	01
44	71812129 K	LIFTRING FL 129/HP 129	01

Seal kit complete:

Part no.	Description
71901650 K	Seal kit complete: consists of all packsets with packset grease and O-rings

Spare part list

Pos	Part no.	Description	Qty.
50	71802110 K	PACKSET FL 110	01
51	72603301	STAGE 110-1275-HC	01
52	71811110 K	OUTER STOPRING FL 110/HP 110 HD	01
53	71807110 K	SLIDER FL 110/GF 110 (2 X 1/2)	01
54	71812110 K	LIFTRING FL 110	01

100	71831091	PISTON HEAD 091 MACHINED	01
101	72402301	PISTON S 091-1280-HC	01
103	71870115 K	O-RING PISTON TOP 091	01
104	71811091 K	OUTER STOPRING FL 091/HP 091 HD	01
105	71807091 K	SLIDER FL 091 (2 X 1/2)	01
106	71870215	O-RING PISTON BOTTOM 091	01
107	71822091	BOTTOM PLATE PISTON 091	01
108	01745012	CIRCLIP 82 DIN 472 (87.5x2.5)	01

120	01702907	TOPNUT NYLOC M48x3 DIN 985 ZP	01
121	71706116	COVER 242-0515 PIN60	01
122	01702956	WASHER M48 DIN 125B ZP	01
123	01702972	DUST COVER FOR COVER 242 YELLOW	01
125	01791941	O-RING COVER D242	01

Notes:

The inner and outer stoprings are pre-mounted in the grooves on spare stages and pistons. Therefore, when ordering new tubes, it is not required to order stopring separately.