

TITAN HOOKLOADER

Capacity 300 kN (-S) H= 1420/1450 mm CH= 1050 mm

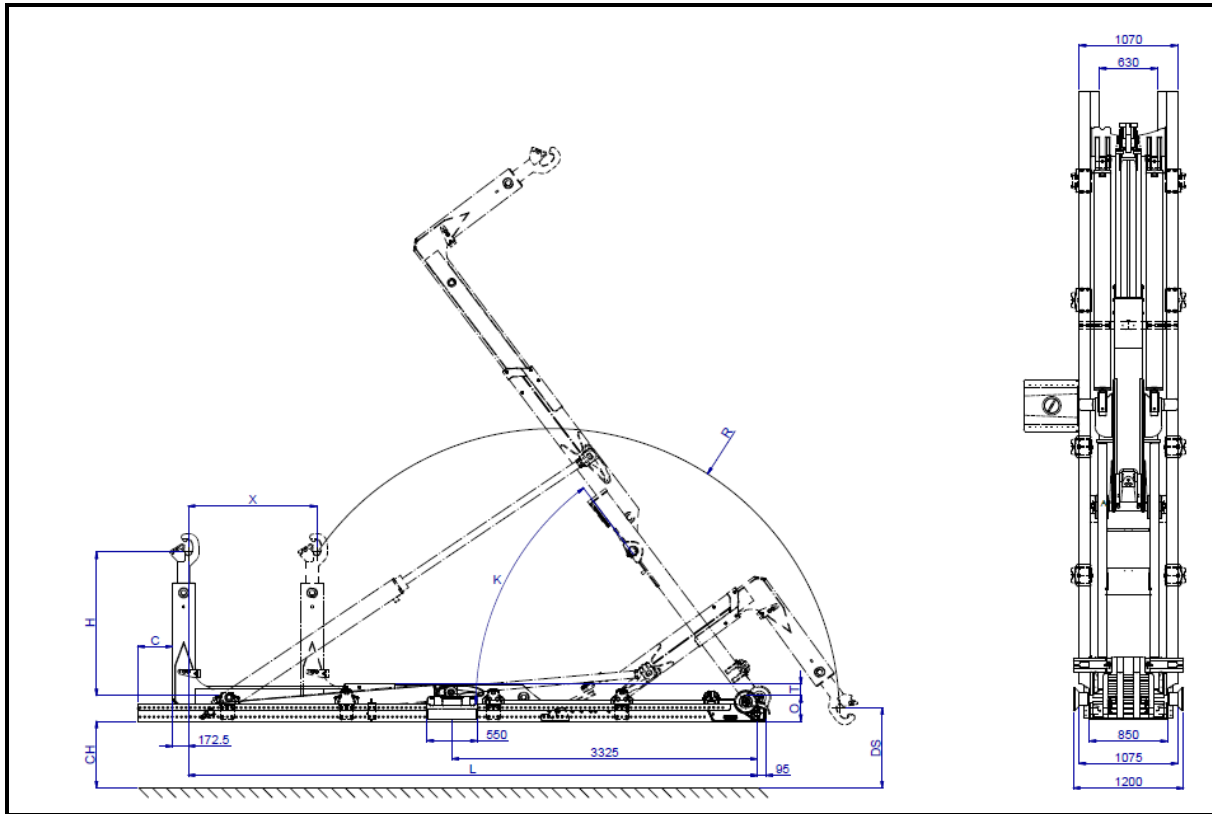

TYPE:	T30-53-S	T30-55-S	T30-57-S	T30-60-S	T30-62-S	T30-65-S	T30-67-S
X (mm)	1200	1200	1200	1400	1400	1400	1500
L (mm)	5300	5500	5700	5950	6200	6450	6650
O (mm)	280	280	280	280	280	280	280
K (°)	54°	51°	48°	53°	50°	48°	48°
R (mm)	2975	2975	2975	3095	3095	3180	3265
T (mm)	130	130	130	130	130	130	130
Weight ¹ (kg)	2800	2825	2850	2900	2925	3050	3075
DS (mm)	1235	1235	1235	1130	1130	1185	1245
Min./max. container length (mm)	4100-6400	4300-6600	4500-6800	4550-7050	4800-7300	5050-7550	5150-7750
C (mm)	200	200	200	200	200	150	150
Loading (time) ² (s)	40	40	40	45	45	45	46
Unloading (time) ² (s)	48	48	48	54	54	54	55
Tipping (time) ² (s)	44	44	44	49	49	49	49
Fast unloading (time) ² (s)	15	15	15	17	17	17	17
Supplied Pump (l/min)	108	108	108	108	108	108	108
Flow (l/min)	120	120	120	120	120	120	120

H = Hook height, CH = Chassis height, DS = Lowest pick up point (depending on hook- and chassis height)

¹ Rough estimation based on a standard system, filled with oil and without mounting kit accessories.

² Rough estimation based on PTO type C, pump 120 l/min., motor 1200rpm, PTO transmission i = 1.0 and dependent on cylinder thickness.

Pressure: 350 bar