

TITAN HOOKLOADER

Capacity 140 kN (-S) H= 1570 mm CH= 1050 mm

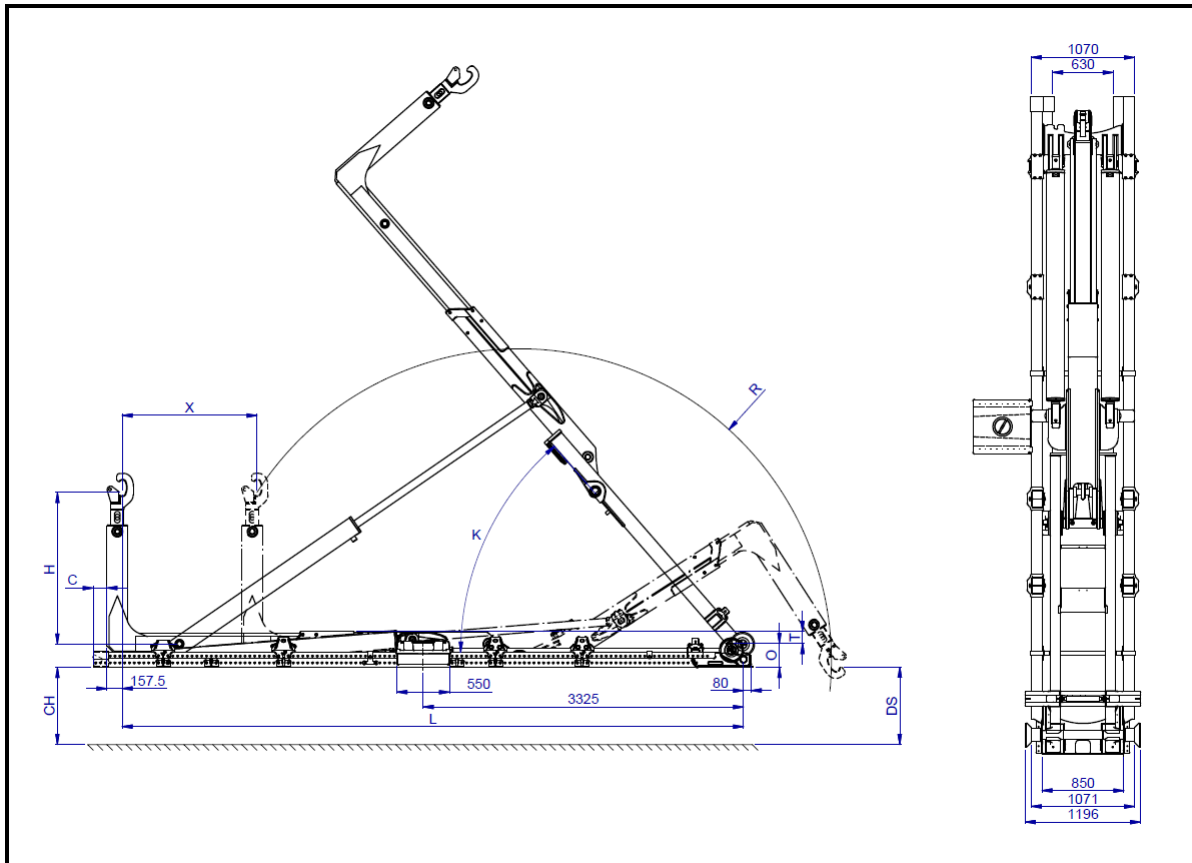

TYPE:	T14-42-S	T14-45-S	T14-47-S	T14-49-S	T14-51-S	T14-53-S	T14-55-S
X (mm)	800	900	1000	1000	1000	1200	1200
L (mm)	4200	4500	4700	4900	5100	5300	5500
O (mm)	220	220	220	220	220	220	220
K (°)	51°	50°	54°	50°	48°	55°	52°
R (mm)	2654	2731	2870	2870	2870	3025	3025
T (mm)	130	130	130	130	130	130	130
Weight ¹ (kg)	1725	1750	1850	1875	1900	2050	2075
DS (mm)	1067	1131	1090	1090	1090	985	985
Min./max. container length (mm)	3450-5300	3650-5500	3700-5800	3900-6000	4050-6150	4100-6400	4300-6600
C (mm)	200	200	200	200	200	200	200
Loading (time) ² (s)	31	32	35	35	35	42	42
Unloading (time) ² (s)	37	38	43	43	43	51	51
Tipping (time) ² (s)	31	31	38	38	38	45	45
Fast unloading (time) ² (s)	11	12	13	13	13	16	16
Supplied Pump (l/min)	47	47	64	64	64	64	64
Flow (l/min)	60	60	80	80	80	80	80

H = Hook height, CH = Chassis height, DS = Lowest pick up point (depending on hook- and chassis height)

¹ Rough estimation based on a standard system, filled with oil and without mounting kit accessories.

² Rough estimation based on PTO type C, pump 60 l/min., motor 1200rpm, PTO transmission i = 1.0 and dependent on cylinder thickness. Pressure: 350 bar