

A	290	mm
B		
C	260	mm
D	450	mm
E	260	mm
F		
G ¹	321	mm
H		
I	200	mm
J	2220	mm
K ¹	521	mm
L		
M ¹	77	mm
N		
O	60	mm
P	145	mm
Q	75	mm
R		
S	209	mm
T ²		
U		
V		

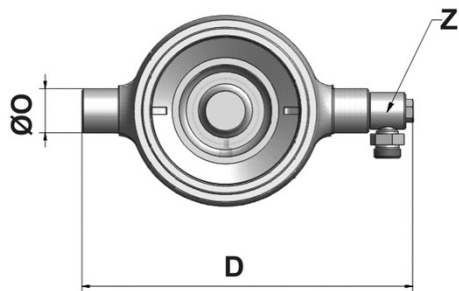

Z Swivelling pressure connection for tube Ø25 mm

¹ Including 20 [-5; +30] mm pull out

3D model is available on request

Specifications

Max. working pressure	300 bar	Max. pump flow (with KO)	65 L/min	Cradle type	None
Total weight	166 kg	Max. pump flow (without KO)	46 L/min	Knock off type	None
Working volume	40 L	Resulting tipping time (with KO)	37 sec		
Total volume	43 L	Resulting tipping time (without KO)	52 sec		
Max. cyl. load (start tipping)	300 kN	Allowable lowering time	37 sec		KO: Hyva knock off

Extension	1	2	3	4	5	6	7	8	9	Total
Effective diameter [mm]	223	193	167	145	125	107	090	074		
Stroke ¹ [mm]	269	290	293	283	280	271	262	274		2220

Technical notes

- This cylinder is a lifting device only. • It should not be used as a structural member and should not be subjected to side loads. • Maximum angle of rotation during operation is 32 deg. • Working pressure depends on the application, but must never exceed the maximum working pressure stated. • Working temperature range is between -40°C and +80°C. • Max. duration of extension is 0.5 hours (excluded hard chromed stages). • Cylinder is painted black (RAL9005) with a thickness conforming to the 480 hours neutral salt spray test as per ISO 9227 (ISO10289, rating 9).

Related documentation

Bracket options: 015BRA16

Mounting instructions: CYL-0024

Oil specifications: OIL-0011

For detailed tipping calculations please refer to: <https://tipper.hyva.com>

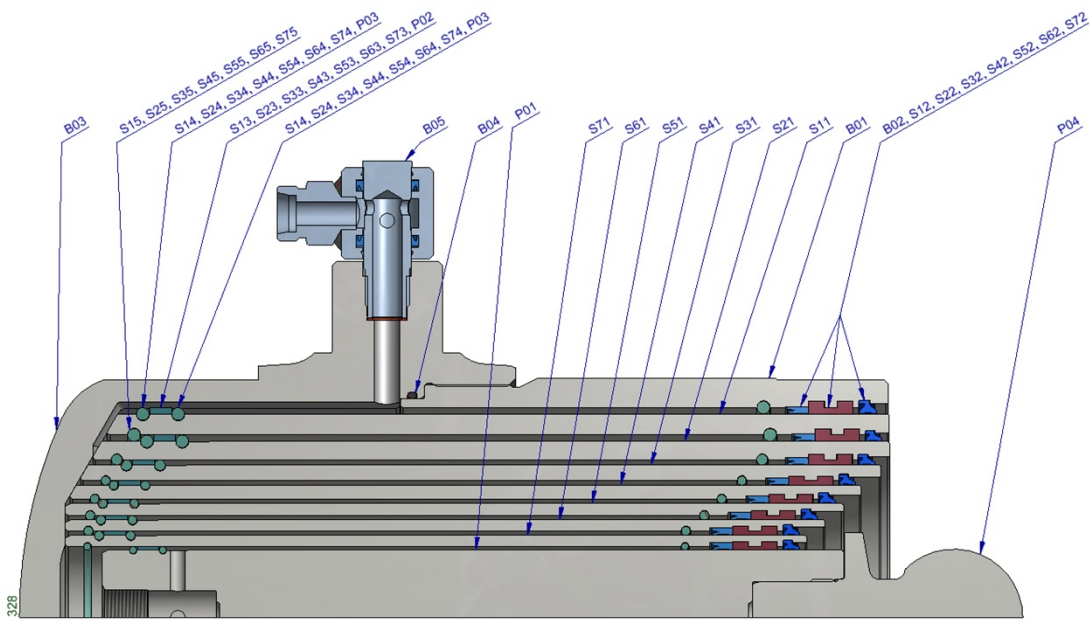

Pos.	Part no.	Description	Qty.
P01	76023731	PISTON 074-373-HC	1
P02	75018551 K	SLIDER 74x12	1
P03	G00322452 K	OUTER STOPRING 74x4	2
P04	75024176 K	SPHERE THREAD Ø75 FL	1

S41	75964001	STAGE 145-400-K73-HC	1
S42	75412145 K	PACKSET 145 KRA/KRM	1
S43	75018438 K	SLIDER 145x12	1
S44	G00322498 K	OUTER STOPRING 145x5	2
S45	G03224921 K	LIFTRING Ø 130 X 5 MB	1

--	--	--	--

S31	75974051	STAGE 167-405-K73-HC	1
S32	75412167 K	PACKSET 167 KRA/KRM	1
S33	75018439 K	SLIDER 167x12	1
S34	G03225091 K	OUTER STOPRING 167x6	2
S35	G03224991 K	LIFTRING Ø 150 X 5 MB	1

S71	75933731	STAGE 090-373-K64-HC	1
S72	75412090 K	PACKSET 090 KRA/KRM	1
S73	75018550 K	SLIDER 90x12	1
S74	G03224655 K	OUTER STOPRING 90x5	2
S75	G03224535 K	LIFTRING Ø 78 X 4 MB	1

S21	75984031	STAGE 193-403-K66-HC	1
S22	75412193 K	PACKSET 193 KRA/KRM	1
S23	75018440 K	SLIDER 193x12	1
S24	G03225233 K	OUTER STOPRING 193x7	2
S25	G03225096 K	LIFTRING Ø 173 X 6 MB	1

S61	75943831	STAGE 107-383-K73-HC	1
S62	75412107 K	PACKSET 107 KRA/KRM	1
S63	75018549 K	SLIDER 107x12	1
S64	G00322477 K	OUTER STOPRING 107x5	2
S65	G00322471 K	LIFTRING Ø 95 X 5 MB	1

S11	75993951	STAGE 223-395-K61-HC	1
S12	75412223 K	PACKSET 223 KRA/KRM	1
S13	75018490 K	SLIDER 223x12	1
S14	G32254975 K	OUTER STOPRING 223x7	2
S15	G00322531 K	LIFTRING Ø 200 X 7 MB	1

S51	75953931	STAGE 125-393-K73-HC	1
S52	75412125 K	PACKSET 125 KRA/KRM	1
S53	75018437 K	SLIDER 125x12	1
S54	G00322489 K	OUTER STOPRING 125x5	2
S55	G00322482 K	LIFTRING Ø 112 X 5 MB	1

B01	75892370	BASE 260-237-K64	1
B02	75412260 K	PACKSET 260 KRA/KRM	1
B03	75410265 K	BASE BOTTOM KRM 260 PIN60 A290	1
B04	G00331007 K	O-RING 242 X 4 70 SHORE	1
B05	75419025 K	COUPLING SET R25	1

Notes

See 015BRA16 for cradle and bracket spare parts.

Seal kit complete

	75420188 K	Consists of all packsets with packset grease and O-rings	
--	------------	--	--

The inner, outer stoprings and liftrings are pre-mounted in the grooves on spare stages and pistons. Therefore, when ordering new tubes, it is not required to order stoprings separately.

For repair instructions see: CYL-0034. Serial no. is located on type plate and near type plate support.