

HYVA CYLINDER

714 06 675



type: UMB 169-7-2360-K245-50-3/4"-HC

tipping weight: 7-19 ton

page # 1 / 2

Stage diameters	front view cylinder		A	230
169			ØC	192
149			G ¹	552
129			I	307
110			K ¹	245
91			M ¹	86
72			ØP	88
53			ØQ	53
		S	322	
		ØW	50	
		X	45	

¹including 20 mm pull-out [tol. -5; +30 mm]

²cylinder is delivered including oil inlet swivel adapter and cup

specifications

total stroke ¹	2360 mm
dry weight cylinder only	97 kg
total volume	27.6 L
working volume	25.4 L
maximum pressure	220 bar
maximum pump flow	33 l/min
maximum allowable thrust first stage ³	15.0 ton
oil inlet	3/4" BSP

technical notes

This cylinder is a lifting device only and may not be used as a structural member or be subjected to side load. Sideload and/or poor alignment might result in cylinder leakage. Hyva therefore strongly recommends the use of a cradle, even in instances where the cylinder only tips to the rear or to the side. The cylinder is painted black RAL9005. For suitable hydraulic oils, please refer to data sheet OIL-0011. For details of available brackets and cradles, please refer data sheet 015BRA06.

Detailed calculations can be made using the HYVA Tipper Program, freely available from tipper.hyva.com.

³The cylinder thrust on the first stage (from the HYVA Tipper Program) must not exceed the maximum allowable (see specifications above).

tipping view

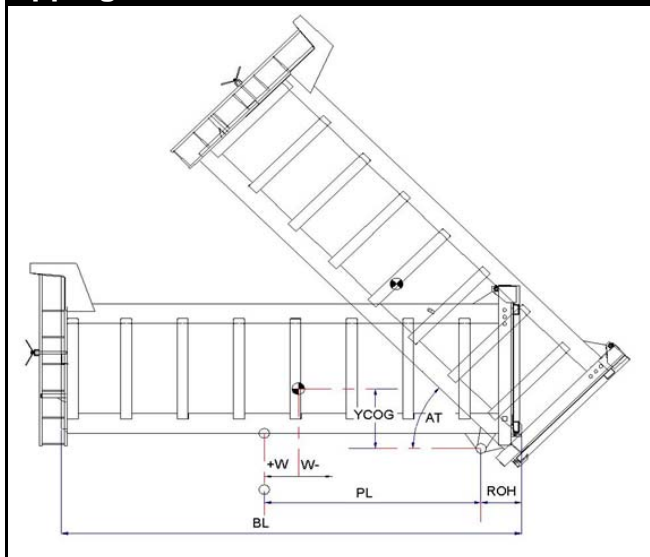

tipping weight

PL	3080			mm	2720		
YCOG	700			mm	700		
ROH	700			mm	700		
BL	7560	6870	6300	mm	6840	6220	5700
CYL w.r.t. COG (W)	0	340	630	mm	0	310	570
	Tipping weight for full stroke of 46°				Tipping weight for full stroke of 52°		
Tipping weight	7	9	10	ton	8	10	11
	Tipping weight for second last stage, up to 39°				Tipping weight for 2nd last stage, up to 45°		
Tipping weight	12	16	18	ton	14	17	19

HYVA CYLINDER

714 06 675

type

UMB 169-7-2360-K245-50-3/4"-HC

page # 2 / 2

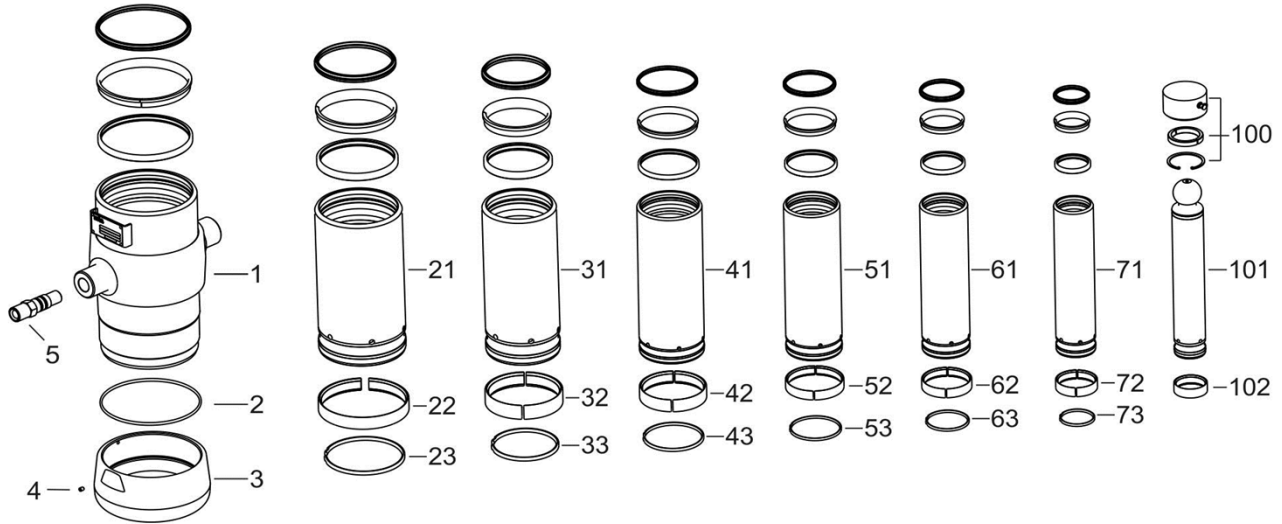

Spare part list

Pos	Part no.	Description	Qty.
1	73507400	BASE 191-0438-N0159	1
2	01226780	O-RING 184 X 4 70 SHORE	1
3	73101050	THREADED BOTTOM UM 191	1
4	01792571	LOCKING SCREW M6X12 INT. HEX. DIN 916	1
5	73103002	OIL INLET ADAPTOR UM 3/4"OT+O-RING	1
21	73606401	STAGE 169-0438-HC	1
22	71807169 K	SLIDER FL 169	1
23	71813169 K	LIFTRING FL 169x5	1
31	73605401	STAGE 149-0438-HC	1
32	71807149 K	SLIDER FL 149	1
33	71812149 K	LIFTRING FL 149/HP 150	1
41	73604401	STAGE 129-0438-HC	1
42	71807129 K	SLIDER FL 129/GF 129 (2 X 1/2)	1
43	71812129 K	LIFTRING FL 129/HP 129	1
51	73603401	STAGE 110-0438-HC	1
52	71807110 K	SLIDER FL 110/GF 110 (2 X 1/2)	1
53	71812110 K	LIFTRING FL 110	1

Spare part list

Pos	Part no.	Description	Qty.
61	73602401	STAGE 091-0438-HC	1
62	71807091 K	SLIDER FL 091 (2 X 1/2)	1
63	71812091 K	LIFTRING FL 091	1
71	73601401	STAGE 072-0438-HC	1
72	71807072 K	SLIDER FL 072 (2 X 1/2)	1
73	71810072 K	INNER STOPRING/LIFTRING FL 072	1
100	01745101	RETAINER KIT UMB D.53	1
101	73400401	PISTON B 053-0474-HC	1
102	71807053 K	SLIDER FL 053 (2 X 1/2)	1

Seal kit complete

Part no.	Description
719 04 670K	Complete packset: Consists of all packsets with packset grease and o-ring.