

HYVA PISTON PUMPS



BENT AXIS TYPE

Hyva

piston pump type :

piston pump 047L-L-4H-BAHP

part number :

145 69 001

Page 1 / 2

rotation :

anti clock wise seen from front side of pump



Fluid	Mineral or synthetic compatible with the following seals: FKM, FPM, HNBR				
Kinematic viscosity suggested	Average ambient temp. (°C)	< -40	-40+10	10+35	> 35
	VG (cSt = mm²/s)	16	22	32	46
Optimale kinematic viscosity			VG= 10 cSt + 100 cSt		
Max kinematic viscosity suggested at the start-up			VG= 750 cSt		
Viscosity index suggested	VI > 100	Working temperature		-40°C + 140°C	
Oil filtering			> 200 bar: 10 µm < 200 bar: 25 µm		
Inlet pressure			0,85 ± 2 bar absolut		
Pump rotation			Left		
Verify that pump is, at least, 100 mm under the minimum level of the tank. Before starting the pump bleed the air.					

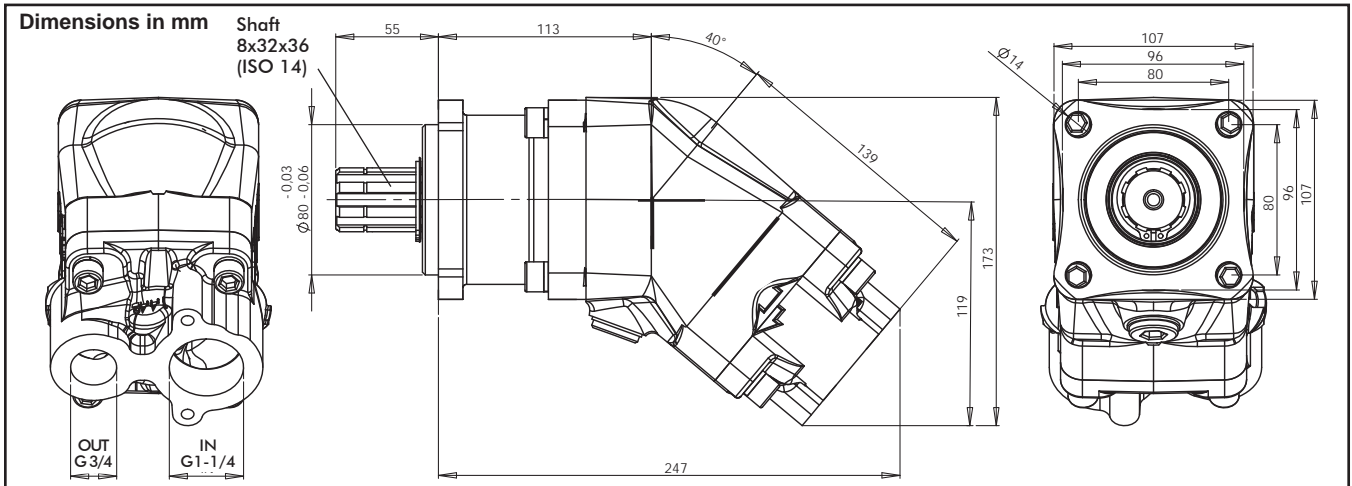

DISPLACEMENT	PRESSURE		SPEED			MIN. SPEED	IN ISO 228	OUT ISO 228	WEIGHT
	P1	P3	V0	V1	V2				
47,13 cm³/rev	350 bar	400 bar	2700 rpm	1900 rpm	2500 rpm	300 rpm	G 1-1/4	G 3/4	13,2 Kg

P1 = Max. continuous pressure (100%)
P3 = Max. peak pressure (6 sec.max)

V0 = Max. continuous speed without load
V1 = Max. continuous speed
V2 = Max. intermittent speed

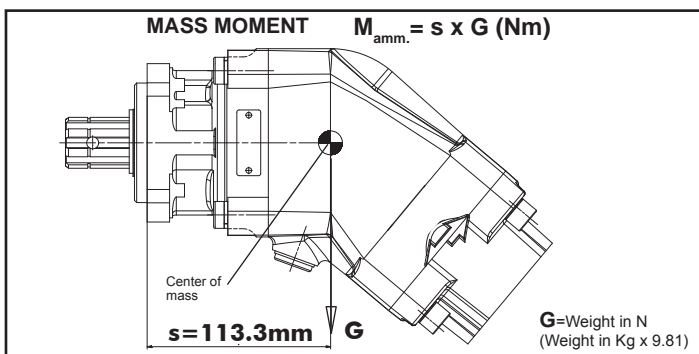

HYVA PISTON PUMPS



BENT AXIS TYPE

Hyva

piston pump type :

piston pump 047L-L-4H-BAHP

part number :

145 69 001

Page 2 / 2

rotation :

anti clock wise seen from front side of pump

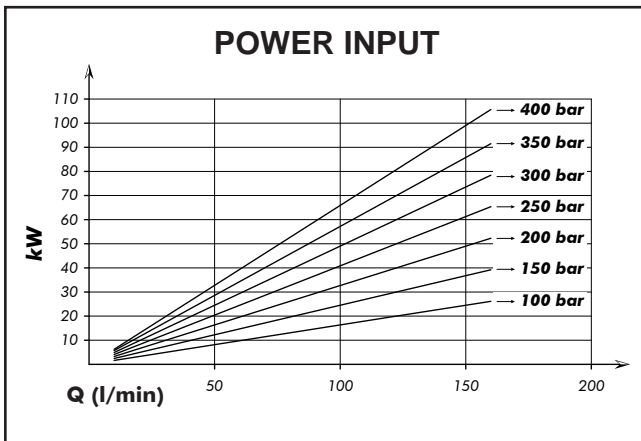
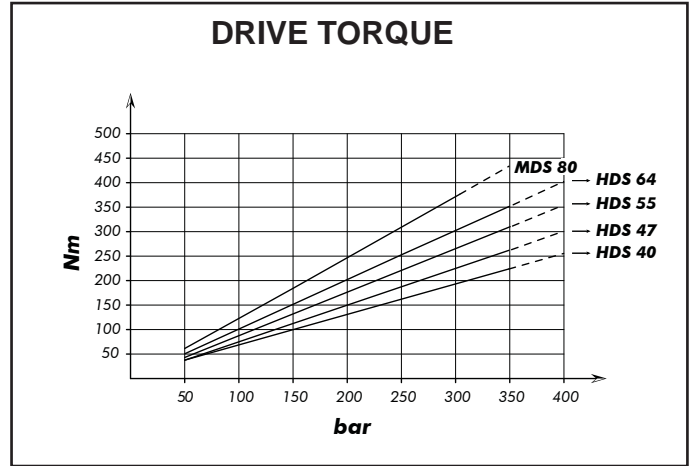
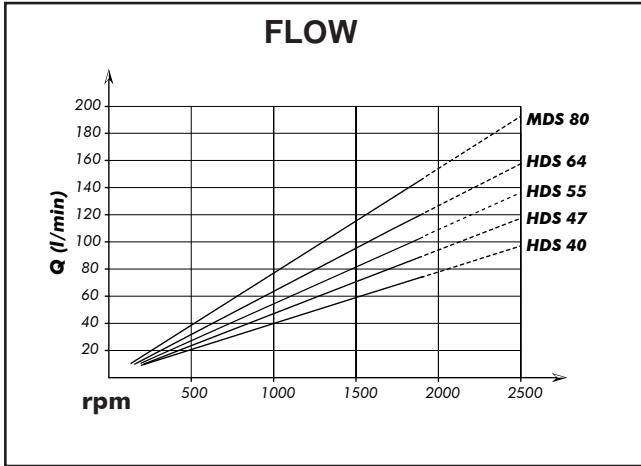

HOW TO CHOOSE THE SUCTION PIPE SIZE

FLOW l/min	MIN PIPE DIAM. inch	FLOW SPEED (m/s)
30	1,25"	0,62
40		0,83
50	1,5"	0,74
60		0,88
80	1,75"	0,84
90		0,94
100	2"	0,85
110		0,93

To ensure the proper suction pipe size the flow speed should not exceed 1m/sec.